

155Mbps ATM-Single Mode Transceiver

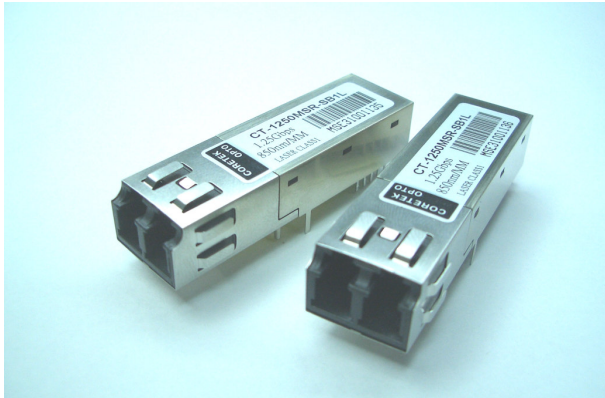

2x5 SFF, Duplex LC Connector, CWDM LD for Single Mode Fiber, RoHS Compliant

Power Budget 33dB

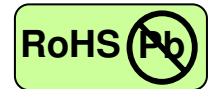

Features

- CWDM 8 wavelengths Transmitter
- Data Rate: 155Mbps, NRZ
- Single +3.3V Power Supply
- RoHS Compliant and Lead-free
- PECL Differential Electrical Interface
- Compliant with Multi-Source Agreement (MSA) Small Form Factor (SFF) 2x5 Footprint
- Duplex LC Connector
- Compliance with 100Base-FX of IEEE802.3u Standard FDDI PMD Standard ATM Standard
- Eye Safety
Designed to meet Laser Class 1 comply with EN60825-1

Applications

- CWDM
- Fast Ethernet
- FDDI
- ATM/SONET OC-3/SDH STM-1
- Single mode fiber links
- Optical-Electrical Interface Conversion

Description

The CT-0155TSR-Cx9L series from Coretek Opto Corp. are the high performance and cost-effective modules for serial optical data communication applications specified for single mode of 155 Mb/s. It operates with +3.3V power supply. The module is intended for single mode fiber, operates at a nominal wavelength of CWDM and complies with Multi-Source Agreement (MSA) Small Form Factor (SFF) 2x5 footprint. Each module consists of a transmitter optical subassembly, a receiver optical subassembly and an electrical subassembly. All of them are housed in a plastic package and the combination produces a reliable component.

The module is a duplex LC transceiver designed for use in fast Ethernet applications and to provide an ATM/SONET OC-3/SDH STM-1 compliant link for 155 Mb/s long reach applications. The characteristics are performed in accordance with ITU-T G.694.2 and G.695.

EMC

Most equipment utilizing high-speed transceivers will be required to meet the following requirements:

- 1) FCC in the United States
- 2) CENELEC EN55022 (CISPR 22) in Europe

To assist the customer in managing the overall equipment EMC performance, the transceivers have been designed to satisfy FCC class B limits and provide good immunity to radio-frequency electromagnetic fields.

Eye Safety

The transceivers have been designed to meet Class 1 eye safety and comply with EN 60825-1.

155Mbps ATM-Single Mode Transceiver



Product Information

Model Number	Wavelength	Operating Voltage & SD Output	Distance	Output Power	Sensitivity
CT-0155TSR-C29L	1470 nm	3.3V PECL DC/DC	100 km	-3 ~ +2 dBm	≤ -36 dBm
	1490 nm				
	1510 nm				
	1530 nm				
	1550 nm				
	1570 nm				
	1590 nm				
CT-0155TSR-CE9L	1470 nm	3.3V TTL DC/DC	100 km	-3 ~ +2 dBm	≤ -36 dBm
	1490 nm				
	1510 nm				
	1530 nm				
	1550 nm				
	1570 nm				
	1590 nm				
	1610 nm				

ABSOLUTE MAX RATINGS

PARAMETER	SYMBOL	MIN	MAX	UNIT	NOTE
Storage Temperature	T_S	-40	85	$^{\circ}\text{C}$	
Supply Voltage	V_{CC}	0	6	V	
Lead Soldering Temperature/Time	T_{SOLD}		260	$^{\circ}\text{C}$	10 sec on lead
Data Input Voltage	---	0	V_{CC}	V	

OPERATING CONDITIONS

PARAMETER	SYMBOL	MIN.	TYP.	MAX.	UNIT	NOTE
Ambient Operating Temperature	T_A	0		70	$^{\circ}\text{C}$	
Supply Voltage	V_{CC}	3.1		3.5	V	

ELECTRICAL CHARACTERISTICS

PARAMETER	SYMBOL	MIN	MAX	UNIT	NOTE
Transmitter					
Transmitter Supply Current	I_{CCT}		200	mA	
TTL Transmit Disable Input Voltage - Low	V_{IL}		0.8	V	
TTL Transmit Disable Input Voltage - High	V_{IH}	$V_{CC}-1.3$	V_{CC}	V	
Receiver					
Receiver Supply Current	I_{CCR}		100	mA	
Receiver Data Output Voltage - Low	$V_{OL}-V_{CC}$	-1.810	-1.620	V	1
Receiver Data Output Voltage - High	$V_{OH}-V_{CC}$	-1.025	-0.880	V	1
Signal Detect Output Voltage - Low (for PECL)	$V_{OL}-V_{CC}$	-1.810	-1.620	V	1
Signal Detect Output Voltage - High (for PECL)	$V_{OH}-V_{CC}$	-1.025	-0.880	V	1
Signal Detect Output Voltage - Low (for TTL)	$V_{OL}-V_{CC}$		0.4	V	1
Signal Detect Output Voltage - High (for TTL)	$V_{OH}-V_{CC}$	2.4		V	1

155Mbps ATM-Single Mode Transceiver



TRANSMITTER ELECTRO-OPTICAL CHARACTERISTICS

PARAMETER	SYMBOL	MIN	TYP.	MAX	UNIT	NOTE
Optical Output Power	P _o	-3		2	dBm	2
Extinction Ratio	ER	10			dB	
Center Wavelength	λ_c	1464.5	1470	1477.5	nm	
		1484.5	1490	1497.5		
		1504.5	1510	1517.5		
		1524.5	1530	1537.5		
		1544.5	1550	1557.5		
		1564.5	1570	1577.5		
		1584.5	1590	1597.5		
		1604.5	1610	1617.5		
Spectral Width (-20dB)	$\Delta \lambda$			1	nm	
Side Mode Suppression Ratio	SMSR	30			dB	
Optical Rise time (10%-90%)	t _r			2.0	ns	3
Optical Fall time (10%-90%)	t _f			2.0	ns	3
Output Eye	Compliant with ITU recommendation G.957					

RECEIVER ELECTRO-OPTICAL CHARACTERISTICS

PARAMETER	SYMBOL	MIN	TYP.	MAX	UNIT	NOTE
Maximum Input Optical Power	P _{max}	-3			dBm	4
Receiver Sensitivity	P _{min}			-36	dBm	4
Operating Wavelength	λ	1260		1620	nm	
Signal Detect - Asserted	P _A			-36	dBm	5
Signal Detect - Deasserted	P _D	-47			dBm	6
Signal Detect - Hysteresis	P _A - P _D	0.5		4	dB	

Notes:

1. These outputs are compatible with 10K, 10KH, 100K ECL and PECL inputs.
2. Measured average power coupled into 9/125 μ m single mode fiber.
3. These are 10-90% values.
4. Measured with 2²³-1 PRBS at BER<10⁻¹⁰
5. Measured on transition – low to high
6. Measured on transition – high to low

BLOCK DIAGRAM OF TRANSCEIVER

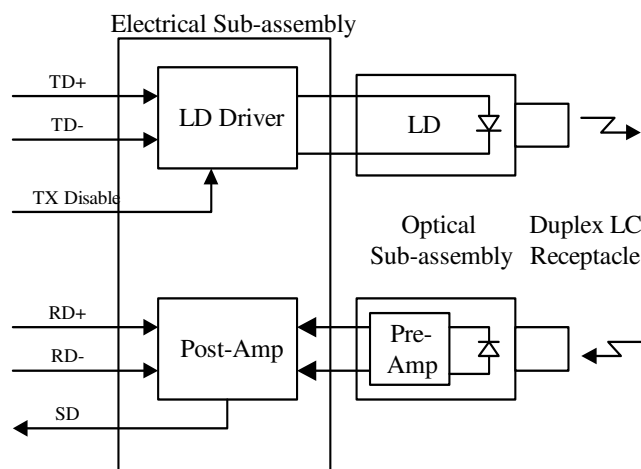

155Mbps ATM-Single Mode Transceiver



PIN OUT DIAGRAM OF TRANSCEIVER

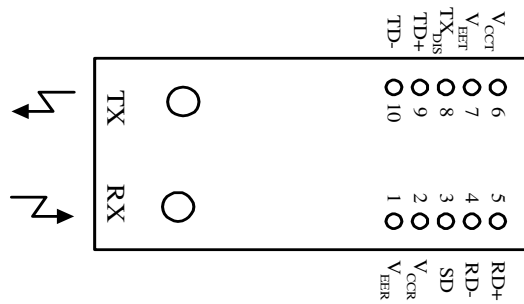

PIN OUT TABLE

Pin	Symbol	Functional Description
Mounting Posts		
The mounting posts are provided for transceiver mechanical attachment to the circuit board. They should not be connected to the circuit ground but can be connected to the chassis ground.		
1	V_{EER}	Receiver Signal Ground
2	V_{CCR}	Receiver Power Supply
3	SD	Signal Detect is a PECL or TTL output. A high level indicates a received optical signal
4	RD-	Receiver Data Inverted Differential Output
5	RD+	Receiver Data Non-inverted Differential Output
6	V_{CCT}	Transmitter Power Supply
7	V_{EET}	Transmitter Signal Ground
8	TX_{DIS}	Transmitter Disable
9	TD+	Transmitter Data Non-inverted Differential Input
10	TD-	Transmitter Data Inverted Differential Input

RECOMMENDED CIRCUIT SCHEMATIC

1) 3.3V SD PECL Module

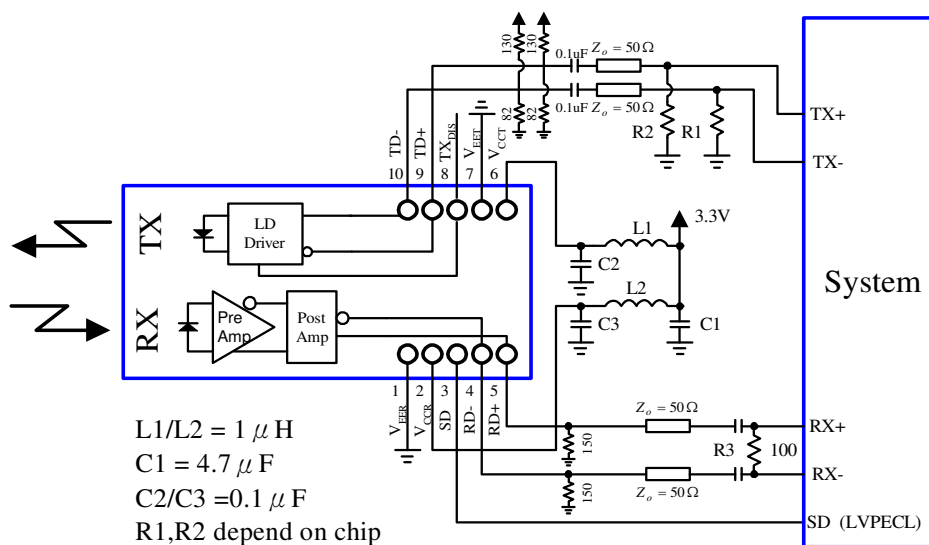

155Mbps ATM-Single Mode Transceiver



2) 3.3V SD TTL Module

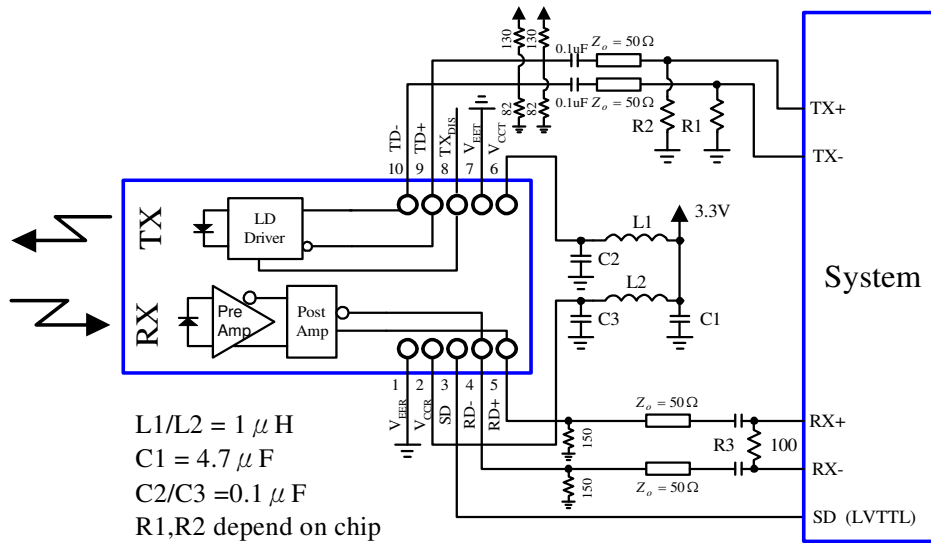

MECHANICAL DIMENSIONS

Units in mm

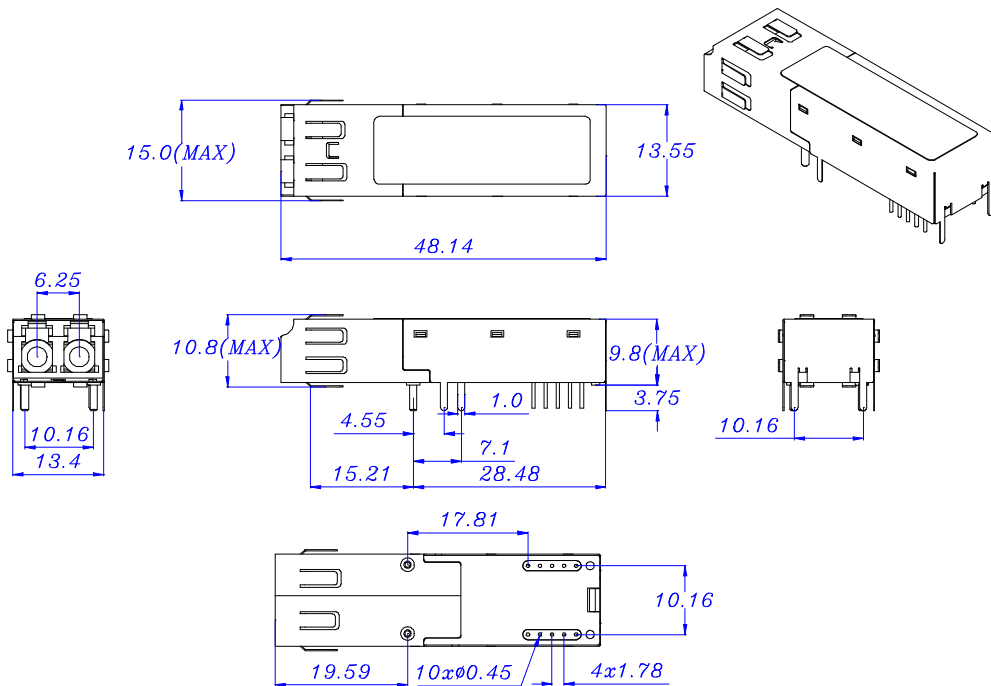

All dimensions are $\pm 0.2\text{mm}$ unless otherwise specified.

155Mbps ATM-Single Mode Transceiver



RECOMMENDED SFF HOST BOARD LAYOUT

Units in mm

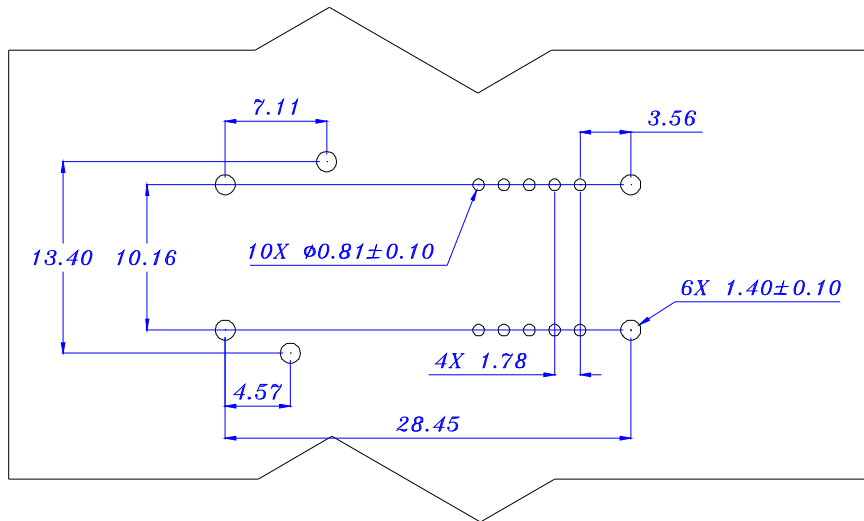

Claim:

CORETEK Opto Corp. reserves the right to make changes in the specification described hereinafter without prior notice.